

MAXICOMPACT

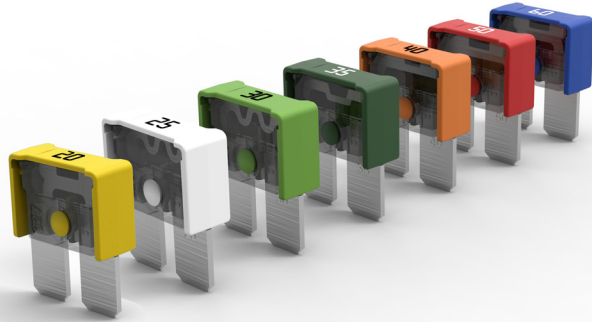

GENERAL DESCRIPTION

Breaking capacity	1000 A
Voltage rating	32 V
Ambient temp. + overheating	-40 °C to +125 °C
Body material	See table below
Cover material	PESU
Cover color	Transparent
Blade material	Zinc
Blade coating	Tin plated
Vibration class compliant with	ISO 16750-3 Test IV
Compliant with	ISO 8820-10 (type L) REACH, RoHS

RATINGS

Size [A]	Color coding	Body material	Expected voltage drop [mV]	ISO cable size [mm ²]	I ² t* [A ² s]	Average cold resistance** [mΩ]
20	Yellow	PA66-GF25	93	1.5	4500	3.4
25	White	PA66-GF25	101	2.5	10500	2.8
30	Light green	PA66-GF25	100	2.5	13500	2.2
35	Dark green	PA66-GF25	89	4.0	12500	1.7
40	Orange	PA66-GF25	85	4.0	15600	1.4
50	Red	PA6T/66-GF30	84	6.0	24500	1.0
60	Blue	PA6T/66-GF30	69	6.0	28200	0.8

*Calculated from breaking capacity test

**At ambient temperature = 23 ± 1 °C, injection time = 0.5 s

OVERALL DIMENSIONS

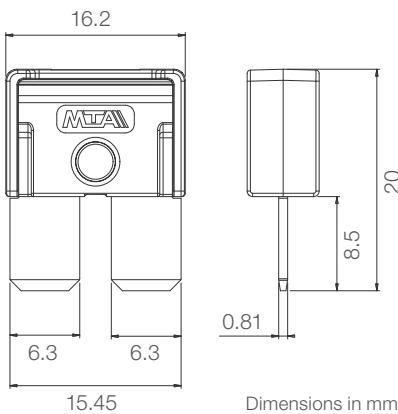

MELTING TIME AND CURVE

Operating time limits:

% I _R	Min [s]	Max [s]
100	360000	∞
135	60	900
160	10	200
200	2	60
350	0.2	7
600	0.04	1

Melting time graph at 23 °C on test module ISO

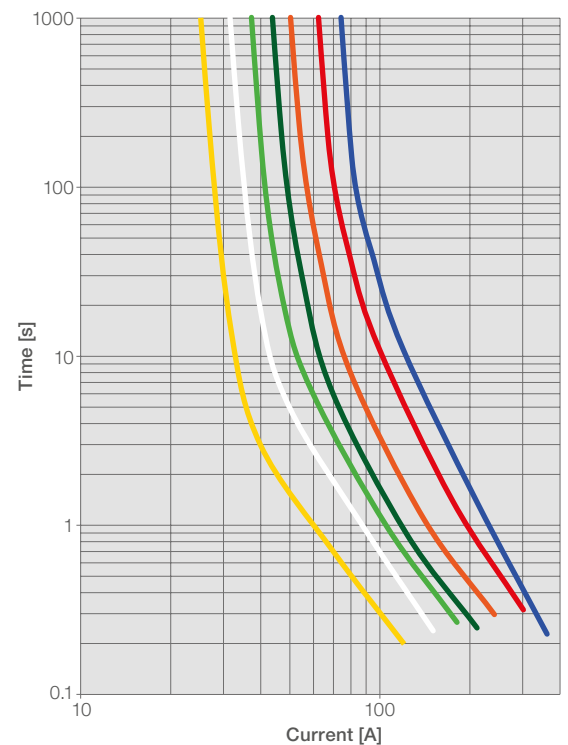

RERATING CURVE

